

# DENSITY- AND CONCENTRATION METER

## SERIES DIMF 2.1

### CHARACTERISTICS

- high cross-section
- direct measurement of density, reference density, or concentration values
- long service life and high reliability
- very high long-term stability
- highest accuracy / repeatability
- maintenance free
- measurement is suitable for CIP and SIP, self- draining and cleaned with a scraper
- simple installation
- independent of mounting position
- resistant to vibration, pressure changes, pulsations, flowrate changes and product viscosity
- no dead zones, no gaskets

### MEASURING PRINCIPLE

The DIMF 2.1 series density/concentration meter is based on the oscillating principle. The fluid to be measured flows through the oscillating element, an oscillating tube with a free cross-section dimension of 25 mm, that is excited electro-magnetically and will oscillate at its natural frequency. Any change in the density of the fluid leads to a change in the natural frequency. These frequency changes will be picked up by the electronic transducer and – allowing for the temperature of the fluid to be measured – converted into a signal proportional to density or concentration.

The measured variable is available as a 4-20 mA output signal and can be shown on the on-site display. Major applications are process control and quality monitoring of fluids in all areas of industry. Due to the high cross-section the DIMF 2.1 is also recommended for use in the main pipe. Difficult measuring materials such as pasty media or media containing pieces of fruit can be measured without blocking the pipe

### TECHNICAL DATA

measured value (*)	$\leq \pm 0,0002 \text{ g/cm}^3$ (DIMF 2.1)
repeatability	$0,00005 \text{ g/cm}^3$
fluid temperature	$-40^\circ\text{C}$ to $+150^\circ\text{C}$
ambient temperature	$-10^\circ\text{C}$ to $+58^\circ\text{C}$ (compact design) separate version upon request
process connection	flanges DN25 or DN50 acc. to pressure rating PN 40 (resp. class 150/300 RF) acc. to DIN 2501 (resp. ANSI B 16.5) other pressure ratings and various food connections are available upon request
electrical connection	power supply 14 – 30 V DC 2 - wire - technique, 4-20 mA, HART®
material	stainless steel 1.4571, Hastelloy C4, other materials upon request
degree of protection	IP 67 (electronics housing)

### MEASURING RANGE

DIMF	Type 2.1
density range	0 to $5 \text{ g/cm}^3$
special feature	proven measuring principle
operating flowrate maximum value	0 to 350 l/min
operating flowrate recommended value approx. especially suitable for	20 to 50 l/min measurement in the main pipe, and where small cross-sections may be unfavourable

(\*) at reference conditions



# DENSITY- AND CONCENTRATION METER

## SERIES DIMF 2.1

### DIMENSIONS

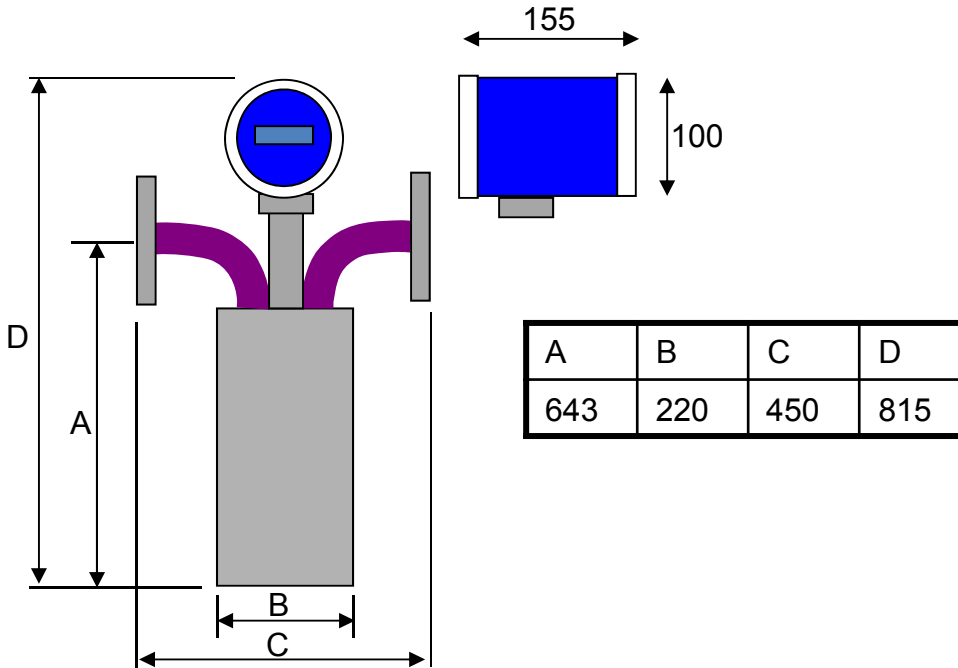

### CONNECTION

... combined with modern electronics suitable for communication

- 2-wire-technique
- 4 - 20 mA - output
- on-site display
- various units of measurement such as kg/m<sup>3</sup>, Ma%, Vol%, °Brix, Bé, °API...
- for special applications: table with up to 400 restart points in the transducer available
- user-friendly and easy to handle due to the display and user interfaces of „SensorPort“, PACTware“, „AMS“, or PDM“
- available DTM drivers support FDT 1.2
- with HART-protocol (Profibus PA in in preparation)
- HandHeldTerminal available

