



**Assembly / Instruction Manual**  
**TRGD**

## Table of contents

	Page
<b>1 General advice</b>	<b>3</b>
1.1 Pump Selection	3
1.2 Product information about the pump	3
1.3 Technical data sheet	3
1.4 Permitted use	3
<b>2 Safety and Advice symbols</b>	<b>3</b>
<b>3 General security advice</b>	<b>4</b>
3.1 Safety instructions relevant to the plant operator	4
3.2 Safety instructions relevant to maintenance, inspection and assembly work	4
3.3 Usage in hazardous areas	5
3.4 Unauthorised modes of operation	5
<b>4 Storage</b>	<b>5</b>
<b>5 Start-up –preparatory work</b>	<b>5</b>
<b>6 Assembly / Instruction Manual TRGD</b>	<b>5</b>
6.1 Fitting position	6
6.2 Direction of rotation	6
6.3 De-aeration	6
6.4 Drive	6
6.5 Connections	6
6.6 Suction conditions	6
6.7 Shaft sealing systems & max. pre-pressures	6
6.8 Viscosity	6
6.9 Speed range	7
6.10 Temperature	7
6.11 Heating and cooling units	7
6.12 Filtration	7
<b>7 Requirement of Returns</b>	<b>7</b>
<b>8 Parts TRGD</b>	<b>7</b>
<b>9 Shaft sealing systems</b>	<b>8</b>
9.1 Radial lip seal ring, standard, no description in order code	8
9.2 Block chamber; type code description: 2F-SP / 3F-SP	8
9.3 Stuffing box; type code description: ST / STz	9
9.4 Mechanical contact seal; type code description: GL	9
9.5 Mag-drive; type code description: MAG	10
<b>10 Maintenance and Repair</b>	<b>10</b>
10.1 General advice	10
10.2 Disassembly and assembly	10
10.2.1 General rules	10
10.2.2 Disassembly of the unit	11
10.2.3 Disassembly of the pump	11
10.2.4 Disassembly of the shaft sealing system	11
10.2.5 Assembly of the pump / sub-system	12
10.3 Spare parts	12
10.4 Further documentation	12
<b>11 Type key</b>	<b>13</b>
<b>12 Connections and Displacements</b>	<b>14</b>
<b>13 Connections and Dimensions</b>	<b>14</b>

## 1 General advice

► This instruction manual is part of the delivery and must be read before working with the pump! Please ensure this advice is followed at all times and keep the manual near the pump.

### ADVICE

No liability is assumed for damage or disruption to process resulting from NOT using and non-observance of this instruction manual. For further development **Beinlich Pump Systems** reserves the right to modify single parts or complete units, while retaining the same characteristics, to improve product quality.

#### 1.1 Pump Selection

The correct selection (version) of type and construction size depending of the application is crucial for a trouble-free and safe operation of the pumps. Owing to the great numbers of various applications and pump versions, the technical specifications in the present document are of general nature. Performance of the units/pumps depends amongst others on size, type, pressure requirement as well the viscosity range.

Please consult Beinlich Pumpen GmbH for an exact selection.

#### 1.2 Product information about the pump

The full type designation is specified in the technical data sheet or the order confirmation. The works serial No. comprises the contract No. and a consecutive serial No. (e. g. 03 / 2456). It is imprinted directly on the rating plate or on the pump.

#### 1.3 Technical data sheet

The technical data sheet is a part of our sales order confirmation and should contain all important technical details as agreed between the purchaser and manufacturer.

#### 1.4 Permitted use

The pump/pump unit is designed only for the field of application listed in the technical data sheet of our order confirmation.

Differing operating conditions will necessitate new contractual agreements.

## 2 Safety and Advice symbols

► It is essential to fully adhere to the safety advice in this instruction manual indicated by:



Warning of mechanical danger, e.g. working on rotating parts



Warning for correct pump operation and maintenance

► The delivered pump must be checked immediately for possible transport damage. If necessary, installation and start-up may have to be postponed. The customer is responsible for the correct installation. Correct performance of the pump as well as the fulfilment of any potential warranty claims depends on the adherence to safety rules.

Make sure that you do not start-up damaged goods!

Read the instruction manual carefully before starting installation, assembly or maintenance. Assembly, installation and start-up as well as repair and maintenance should be done only by qualified professionals with consideration given to:

- this instruction manual,
- all other paperwork which is connected to this project, user manuals and schematics,
- all current domestic and internationally applicable regulations and accident precautions.



Assembly and maintenance work is only permitted if the system is taken completely off-line! The unit must be protected against any accidental switch-on!

### 3.1 Safety instructions relevant to the plant operator

- If hot or cold machine components involve hazards, they must be guarded against accidental contact on site.
- Guards for moving parts (e. g. coupling) must not be removed from the machine while in operation.
- Any leakage of hazardous (e. g. explosive, toxic, hot) fluids (e.g. from the shaft seal) must be drained away so as to prevent any risk to persons or the environment. Statutory regulations are to be complied with.
- Hazards resulting from electricity are to be prevented (see for example, the VDE Specifications and the bye – laws of the local power supply utilities).



Stripping down the pump within the warranty period is only allowed after consulting with **Beinlich Pump Systems**.

### 3.2 Safety instructions relevant to maintenance, inspection and assembly work

It shall be the plant operator's responsibility to ensure that all maintenance, inspection and assembly work is performed by authorised and qualified personnel who have adequately familiarised themselves with the subject matter by studying this manual in detail.

Any work on the machine shall only be performed when it is at a standstill, it being imperative that the procedure for shutting down the machine described in this manual is followed.

On completion of work all safety and protective facilities must be re-installed and made operative again.

Prior to restarting the machine, the instructions relevant to "Initial commissioning" must be observed.

### 3.3 Use in hazardous areas

Please see the addendum to this instruction manual "use in hazardous areas"

### 3.4 Unauthorised modes of operation

The reliability of the machine delivered will be only guaranteed if it is used in the manner intended, in accordance with Section 1 of this manual. The limit values specified in the data sheet must under no circumstances be exceeded.

## 4 Storage

► Please consider the following:

- store indoors only
- ambient temperature should be 25 °C / 77 °F, relative humidity max. 80%
- the unit should be protected against UV-rays and direct sunshine
- it must not be stored near aggressive or corrosive substances
- the pump shaft should be turned 1 to 2 rotations to make sure the internal parts are lubricated by the medium
- the units have to be protected against mechanical force or external load

## 5 Start-up – preparatory work

► The pump should only be started if:

- the type code agrees with the order confirmation.
- it is free of breakage and damage.
- in particular the shaft sealing, plugs and covers are not damaged.
- no leakage is visible.
- there is no corrosion or other evidence of incorrect storage.
- all packing has been removed completely.

All connection ports and drive shafts should be free of protective components (e.g. plugs) and contamination.



#### **IMPORTANT**



The lip seals of the shaft seal ring must NOT come into contact with any kind of solvent >> material damage possible

## 6 Assembly / Instruction Manual TRGD



#### **PLEASE NOTE**

Because it is a valve-checked pump a pressure control valve is always required in the discharge line! This avoids free flow through the pump during shutdown! Such free flow can occur due to inlet pressure and is NOT a malfunction!

- 6.1 Fitting position** any/user defined
- 6.2 Direction of rotation**  
any/user defined
- 6.3 De-aeration** With the pump running at low pressure (i.e. in re-circulation) loosen the bleed screw so that fluid emerges from the pump housing (Note: DO NOT remove the bleed screw completely). Continue running until fluid without air bubbles emerges from the bleed port. Then re-tighten the screw.
-  **Warning** Do not bleed or loosen the bleed screw during high pressure operation of the pump.
- 6.4 Drive** Must not generate radial forces!! The drive should preferably connect by an elastic coupling (e.g. Softex® or Starex® couplings from HBE). If using a belt drive or a gear wheel drive one MUST have a support-bearing to avoid potential radial/axial forces. The clutch or pulley must be used with ISA-fit H7, and should never be installed using hammer blows as this will destroy the pump's running characteristics.
- 6.5 Connections** BSP inlet threads or flanges (please check the type description!) Due to the danger of contamination, compounds such as hemp and sealing cement should NOT be used.
- 6.6 Suction conditions**  
This valve-controlled radial piston pump requires mandatory pre-pressure!  
The inlet pressure depends on the shaft sealing system.  
Bent pipes with small radiuses, constricting pipes and closable valves are to be avoided.
-  **ATTENTION** Because it is a valve-checked radial piston pump it is absolutely necessary to have an inlet pressure of 2 bar minimum!
- 6.7 Shaft sealing systems & max. pre-pressures**
- |                               |                                      |
|-------------------------------|--------------------------------------|
| lip seal ring / block chamber | 4 bar (60 psi)                       |
| packing gland seal            | 50 bar (725 psi)                     |
| mechanical contact seal       | 15 bar (218 psi)                     |
| magnetic coupling             | 20 bar (290 psi) (others on inquiry) |
- 6.8 Viscosity** The pistons are matched to viscosity ranges: between 1 cPs and 100 cPs and between 100 cPs and 5000 cPs (others after consultation)
- 6.9 Speed range** Max. 1800 rpm (depending on viscosity!) depending on the number of pistons pulsation can occur below 100 rpm

**6.10 Temperature** See type description. The minimum and maximum temperature depend on the sealing material!

**6.11 Heating and cooling units**  
Some units are made with heating cartridges, heating jackets or heating ports and will be heated up or cooled down electrically, with liquid or with a gas medium.

**6.12 Filtration** We recommend using a suitably sized filter with a filter mesh of 25 µm. Before start-up, the whole system must be cleaned very carefully of all foreign objects .

## 7 Requirement of Returns



### ATTENTION

**Only cleaned, liquid-free pumps can be accepted by us for maintenance or repair. We reserve the right to send back contaminated pumps at the expense of the customer.**

**To speed up a potential breakdown situation we would ask customers to complete an available non conformity report and to send it back with the pump! Please ask Beinlich Pumps for the report form.**

## 8 Parts TRGD

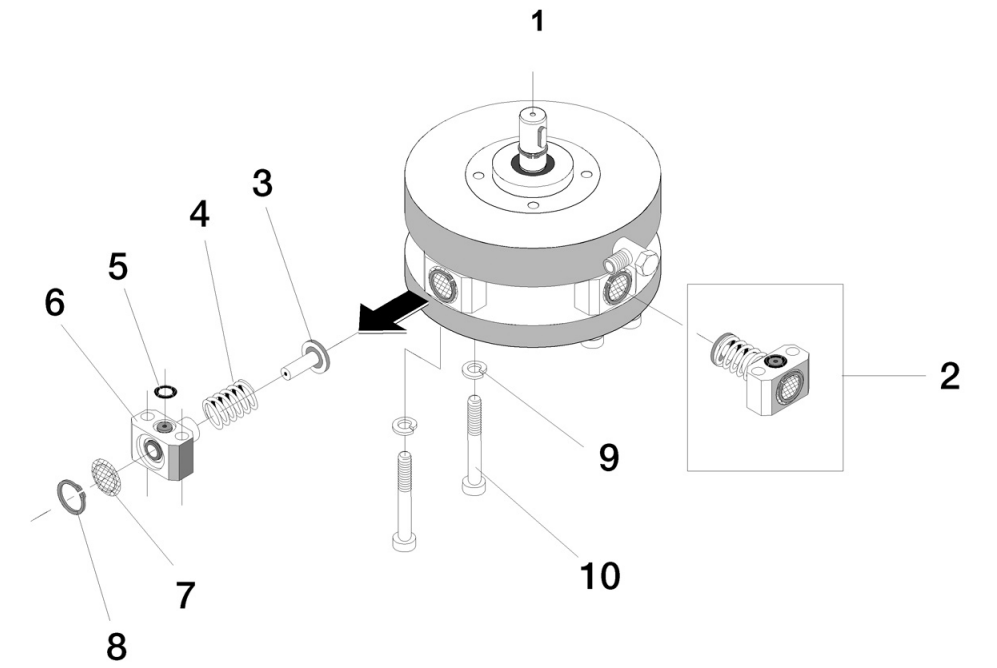

- |                         |                         |                  |                        |                 |
|-------------------------|-------------------------|------------------|------------------------|-----------------|
| <b>1</b> drive shaft    | <b>2</b> piston element | <b>3</b> piston  | <b>4</b> piston spring | <b>5</b> o-ring |
| <b>6</b> piston housing | <b>7</b> screen basket  | <b>8</b> circlip | <b>9</b> snap ring     | <b>10</b> bolt  |
- picture shows TRGD without housing

► It is possible to have combinations of different shaft sealing systems, e.g. block chamber with mechanical contact seal. These need to be maintained or checked in particular ways.

### 9.1 Radial lip seal ring, standard, no description in order code

The radial lip seal ring is maintenance free. If it leaks, it has to be renewed. If the drive shaft is worn it must be replaced too, because an effective seal will no longer be possible. In this condition a new lip seal ring will be damaged immediately.

### 9.2 Block chamber; type code description: 2F-SP / 3F-SP

With two or three lip seal rings. The block chamber should be monitored to ensure the fluid level is constant and should be topped up as necessary. Changes in the block chamber fluid level indicates wear on the lip seal ring and/or the drive shaft!

If the drive shaft is worn it must be replaced too, because an effective seal will no longer be possible. In this condition a new lip seal ring will be damaged immediately.

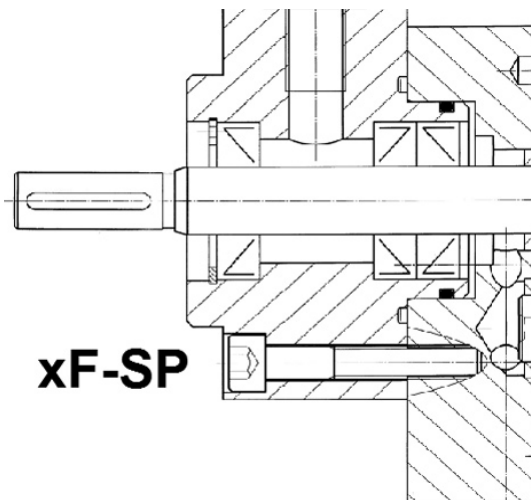



### 9.3 Stuffing box; type code description: ST / STz

The packing gland cover MUST NOT be tightened too hard. A small outflow is required to reduce frictional heat. If the leakage increases during prolonged running it is necessary to tighten the three bolts evenly (ST), or tighten the gland nut 1/6 of a turn (STz) to reduce the leakage. In the ST version, ensure that the packing gland cover is tightened down evenly! If an adjustment of the bolts or the gland nut is no longer possible only one black packing ring needs to be renewed.

A complete change of all the rings is not normally necessary. If the drive shaft shows score marks, it has to be changed to make sure that it will be sealed after installing the new packing rings. The joints of each packing ring must be installed at a 90° angle to each other. The correct sequence of the rings is two black rings in the centre with two white rings on either side.

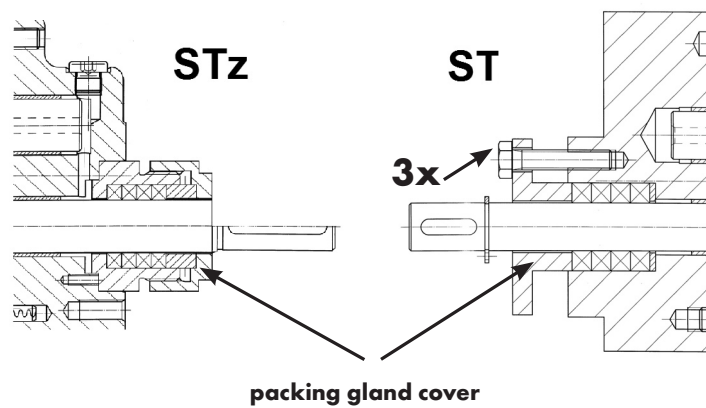

### 9.4 Mechanical contact seal; type code description: GL

Maintenance is simply a visual inspection for leakage. A small perspiration is typical. If the mechanical contact seal is leaking it has to be renewed. During repair please double check the pump bearing clearances.

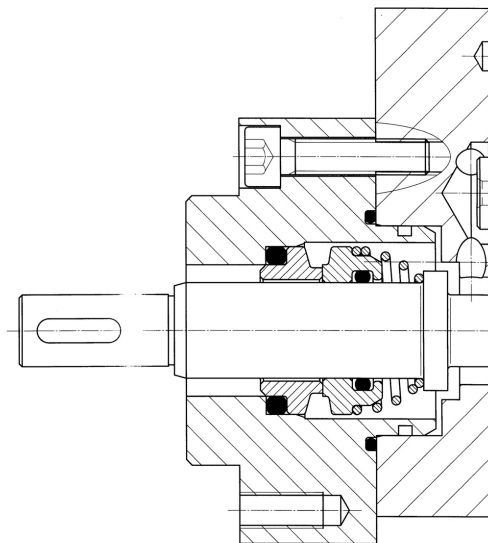

### 9.5 **Mag-drive; type code description: MAG**

The magnetic coupling is maintenance free. The medium will be sealed hermetically by the canister. Maintenance is simply a visual inspection for leakage.



#### **ATTENTION**

The operator **MUST** follow the safety advice when using a magnetic coupling. During the assembly of the motor to the pump consideration must be given to the attractive forces of the magnetic coupling! Furthermore we recommend the use of a cooling pump when using a mag-drive larger than 80 Nm to reduce the heat build-up. (Please see also the user manual of the mag-drive manufacturer **DST**)

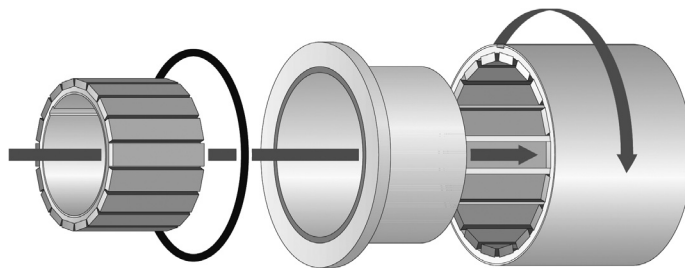

## **10 Maintenance and Repair**

### **10.1 General advice**

Beinlich radial piston pumps are maintenance-free under normal conditions. A continuous check of the technical parameters is recommended. The use of corresponding control equipment such as working hour counter, pressure and temperature switches, etc. should be made in relation to general requirements.

During on-going maintenance of the unit please consider the following:

- check that all connection bolts and pipe-work is tightened correctly and if not that they are retightened.
- inspect the alignment of the coupling. Check the flexible component for wear.
- check for leaks, especially the shaft sealing.

### **10.2 Disassembly and assembly**

#### **10.2.1 General Rules**

Before disassembly the unit has to be protected against inadvertent start-up. The isolator valves must be closed and the pump must have cooled/warmed to ambient temperature.

### 10.2.2 Disassembly of the unit

1. interrupt power supply
2. remove all extra connections/  
piping

#### 3a. unit on a base plate (FB):

- 3a.1. remove coupling cover; disconnect motor; remove motor from base plate by decoupling the motor from the pump;

- 3a.2. loosen suction and pressure connections

- 3a.3. remove pump from ground plate

#### 3b. unit with bell housing (FcV/FcB):

- disconnect motor  
remove motor

- 3b.1. loosen suction and pressure connections

- 3b.2. disassemble pump with bell housing from motor

### 10.2.3 Disassembly of the pump

Please use sectional drawing. Please check the alignment of each part relative to the others. We recommend to mark the parts and number serially.

1. remove shaft sealing system (see 10.2.4)
2. un-screw hexagonal socket screws from the back plate
3. remove circlip on the back of the drive shaft; remove the Allen screw on the rear bearing plate and remove the piston housing (take care of the spring load)
4. extract the rear bearing plate and remove the spacer ring in front of the bearing
5. extract ball bearing with eccentric
6. remove the second spacer ring and press out the drive shaft to the front.
7. extract the ball bearing from the pressure port plate

### 10.2.4 Disassembly of the shaft sealing system

	block chamber (2F-SP/3F-SP)	stuffing box (ST/STz)		mechanical contact seal (GL)	mag-drive (MAG)
		ST	STZ		
1	remove circlip	un-srew the 3 bolts of the cover	remove central taper	un-screw shaft seal carrier	un-screw canister
2	remove lip seal rings	remove packing rings	remove packing rings	remove cover carefully with the built in mechanical contact seal	undo safety screw on the inner rotor
3	-	-	-	undo set screw on the ring-unit	draw off the inner rotor
4	-	-	-	pull away the ring unit from the drive shaft	remove mag-flange

**Please perform the disassembly carefully! Because of risk of breakage please do not use any significant force!**

### 10.2.5 **Assembly of the pump / sub-system**

Assembly should be carried out in accordance with general good practice mechanical engineering guidelines! Seals should be checked for damage before use and if necessary renewed. PTFE seals should be renewed routinely. All old sealant must be removed completely. The assembly should be carried out in the reverse order to the disassembly (please see also 10.2.4).

### 10.3 **Spare parts**

When ordering spare parts please use:

- order number (on type plate)
- article number (on type plate)
- part number from parts list
- quantity required

We only accept liability for warranty on original **Beinlich Pump Systems** parts. We recommend keeping a complete spare pump for 24/7 operations to have a spare available during return or repair. When ordering spare parts please use our parts list in conjunction with the sectional drawing. We would like to point out expressly that the use of non **Beinlich Pump Systems** spare parts and equipment is not authorised! The installation and use of such parts can negatively affect designed and specified performance. This can jeopardise the safe use of our pumps and/or sub-systems.

**Beinlich Pump Systems does not accept any liability or warranty for** any losses incurred by using non original spare parts and/or original equipment .

### 10.4 **Further documentation**

All relevant information can be found in the technical data sheet and the order confirmation.

# 11

## Type key

TRGD 08 / 5 - 2,50 - 550 - FcV - R / MAG (7-G) / M(0,37) B35 / PTFE

<b>type</b>	
TRGD=	radial piston dosing pump
<b>diameter of pistons</b>	
(see data sheet "displacements" and "flow in cc/rev @ # of pistons")	
<b>number of pistons</b>	
(see data sheet "displacements" and "flow in cc/rev @ # of pistons")	
<b>displacement</b>	
in l/min at 1450 rpm	
<b>maximum working pressure</b>	
in bar	
<b>mounting</b>	
F=	mounting bores on pump
FB=	foot bracket
FcV=	bell housing
FcB=	bell housing with foot bracket
<b>connection</b>	
R=	BSP inlet threats
T=	SAE-flanges
<b>coupling</b>	
K=	mechanical coupling
MAG=	mag-drive ( torque in Nm)
	G = capsulated
	N = non capsulated
<b>motor</b>	
M=	AC or DC motor
UM=	motor with frequency drive
GM=	gear box motor
GUM=	gear box motor with frequency
<b>motor construction</b>	
B3=	foot mounting
B5=	flange mounting
B35=	foot-/flange mounting
EX=	Ex-motors
<b>specials</b>	
3F-SP=	3 lip block chamber
ST=	packing gland bi-directional
STz=	packing gland with central taper
PTFE=	PTFE sealing
...=	other specials

piston diameter (mm)	cc/piston
5	0,14
6	0,2
8	0,38
10	0,59
12	0,86
13	1
14	1,17
15	1,34

		flow in cc/rev @ # of pistons					
piston diameter (mm)	# of pistons	3	4	5	6	7	8
5	1-stage	0,42	0,56	0,70	0,84	0,98	1,12
6		0,60	0,80	1,00	1,20	1,40	1,60
8		1,14	1,52	1,90	2,28	2,66	3,04
10		1,77	2,36	2,95	3,54	4,13	4,72
12		2,58	3,44	4,30	5,16	6,02	6,88
13		3,00	4,00	5,00	6,00	7,00	8,00
14		3,51	4,68	5,85	7,02	8,19	9,36
15	4,02	5,36	6,70	8,04	9,38	10,72	
piston diameter (mm)	# of pistons	6	8	10	12	14	16
5	2-stage	0,84	1,12	1,40	1,68	1,96	2,24
6		1,20	1,60	2,00	2,40	2,80	3,20
8		2,28	3,04	3,80	4,56	5,32	6,08
10		3,54	4,72	5,90	7,08	8,26	9,44
12		5,16	6,88	8,60	10,32	12,04	13,76
13		6,00	8,00	10,00	12,00	14,00	16,00
14		7,02	9,36	11,70	14,04	16,38	18,72
15	8,04	10,72	13,40	16,08	18,76	21,44	
piston diameter (mm)	# of pistons	9	12	15	18	21	24
5	3-stage	1,26	1,68	2,10	2,52	2,94	3,36
6		1,80	2,40	3,00	3,60	4,20	4,80
8		3,42	4,56	5,70	6,84	7,98	9,12
10		5,31	7,08	8,85	10,62	12,39	14,16
12		7,74	10,32	12,90	15,48	18,06	20,64
13		9,00	12,00	15,00	18,00	21,00	24,00
14		10,53	14,04	17,55	21,06	24,57	28,08
15	12,06	16,08	20,10	24,12	28,14	32,16	
piston diameter (mm)	# of pistons	12	16	20	24	28	32
5	4-stage	1,68	2,24	2,80	3,36	3,92	4,48
6		2,40	3,20	4,00	4,80	5,60	6,40
8		4,56	6,08	7,60	9,12	10,64	12,16
10		7,08	9,44	11,80	14,16	16,52	18,88
12		10,32	13,76	17,20	20,64	24,08	27,52
13		12,00	16,00	20,00	24,00	28,00	32,00
14		14,04	18,72	23,40	28,08	32,76	37,44
15	16,08	21,44	26,80	32,16	37,52	42,88	

## 13 Connections and Dimensions

optional port sizes in inches (BSP)					
suction TR	pressure TR	suction TRG	pressure TRG	suction TRGD	pressure TRGD
-	1/4"	3/4"	1/4"	3/4"	3/8"
		1"	3/8"		
		1 1/4"	1/2"	1 1/4"	3/4"
		1 1/2"	3/4"		

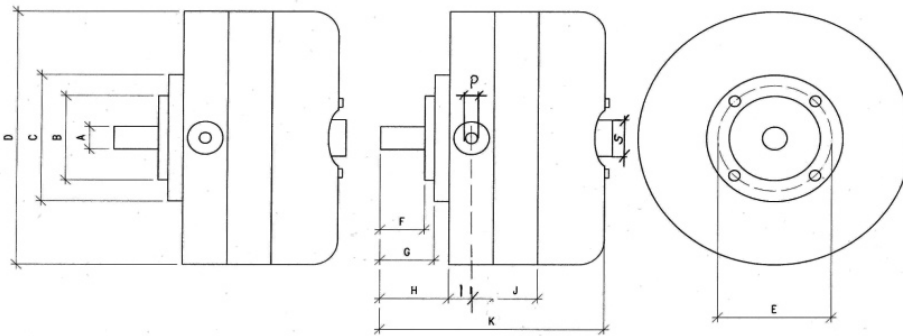

millimeters													
	A	B	C	D	E	F	G	H	I	J	K	fitting key	
TR 1 & 2	18	60	100	175	78	45	60	75	15		167	199	A 6x6x36 DIN 6885/1
TRGD 1 & 2	20	80	118	210	100	40	51	64	14	70	181	213	A 6x6x32 DIN 6885/1
TR 3 & 4	25	60	115	210	78	45	53	73	15		282	350	A 6x6x36 DIN 6885/1
TRGD 3 & 4	25	80	118	230	100	50	70	83	14/20	100	321	384	A 6x6x40 DIN 6885/1

1 & 2 means 1- and 2- stage pump

3 & 4 means 3- and 4- stage pump

all dimensions approximate and only for the standard range

**beinlich**.*pump*  
systems

**Beinlich Pumpen GmbH**

Gewerbestr. 29

58285 Gevelsberg/Germany

Phone +49 (0) 23 32 / 55 86 0

Fax +49 (0) 23 32 / 55 86 31

info@beinlich-pumps.com

www.beinlich-pumps.com



www.e-holding.de