

XV-1P

unidirectional pump -series XV

STANDARD EUROPEAN PUMP
 ø25.4 FLANGE -TAPER SHAFT



X 1 P 25 02 F I I A

Series	X	series XV
Group	1	group 1
Category	P	unidirectional pump
Displacement	25	3.8
Flange	02	Ø25.4 STANDARD EUROPEAN right rotation
Shaft	F	CO001 -Tapered 1:8 -ø10 -M7x1 -key thk.2.4
Body	IN	I inlet -Ø30 Ø12 M6
	OUT	I outlet -Ø30 Ø12 M6
Cover	A	standard

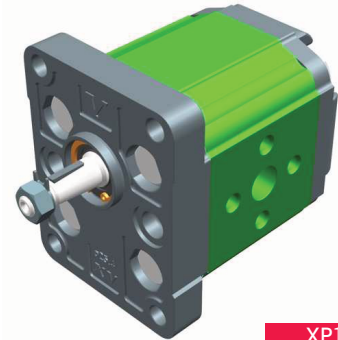

XP101

Technical data table

TYPE	Displacement cm ³ /rev	Max. Pressure		CODE	
		P1 bar	P3 bar	Left rotation	
				Right rotation	
XV-1P/0.9	0.91	240	280	X 1 P 16 01 F I I A	X 1 P 16 02 F I I A
XV-1P/1.2	1.17	250	290	X 1 P 17 01 F I I A	X 1 P 17 02 F I I A
XV-1P/1.7	1.56	250	290	X 1 P 18 01 F I I A	X 1 P 18 02 F I I A
XV-1P/2.2	2.08	250	290	X 1 P 20 01 F I I A	X 1 P 20 02 F I I A
XV-1P/2.6	2.60	250	300	X 1 P 21 01 F I I A	X 1 P 21 02 F I I A
XV-1P/3.2	3.12	250	300	X 1 P 23 01 F I I A	X 1 P 23 02 F I I A
XV-1P/3.8	3.64	250	300	X 1 P 25 01 F I I A	X 1 P 25 02 F I I A
XV-1P/4.3	4.16	250	300	X 1 P 27 01 F I I A	X 1 P 27 02 F I I A
XV-1P/4.9	4.94	250	300	X 1 P 29 01 F I I A	X 1 P 29 02 F I I A
XV-1P/5.9	5.85	250	300	X 1 P 31 01 F I I A	X 1 P 31 02 F I I A
XV-1P/6.5	6.50	250	300	X 1 P 32 01 F I I A	X 1 P 32 02 F I I A
XV-1P/7.8	7.54	220	260	X 1 P 34 01 F I I A	X 1 P 34 02 F I I A
XV-1P/9.8	9.88	190	230	X 1 P 36 01 F I I A	X 1 P 36 02 F I I A

P1) Max. working pressure - P3) Max. peak pressure

For heavy-duty applications, it is recommended to check the admissible torque of the shaft

Dimensions table

TYPE	Weight kg	A	B	C	D	E	F	D	E	F
		mm	mm	mm	IN			OUT		
XV-1P/0.9	0.950	78,1	37,3	66,1	ø12	30	M6x1	ø12	30	M6x1
XV-1P/1.2	0.970	79,0	37,8	67,0	ø12	30	M6x1	ø12	30	M6x1
XV-1P/1.7	1.010	80,5	38,5	68,5	ø12	30	M6x1	ø12	30	M6x1
XV-1P/2.2	1.030	82,5	39,5	70,5	ø12	30	M6x1	ø12	30	M6x1
XV-1P/2.6	1.060	84,5	40,5	72,5	ø12	30	M6x1	ø12	30	M6x1
XV-1P/3.2	1.090	86,5	41,5	74,5	ø12	30	M6x1	ø12	30	M6x1
XV-1P/3.8	1.120	88,5	42,5	76,5	ø12	30	M6x1	ø12	30	M6x1
XV-1P/4.3	1.170	90,5	43,5	78,5	ø12	30	M6x1	ø12	30	M6x1
XV-1P/4.9	1.200	93,5	45,0	81,5	ø12	30	M6x1	ø12	30	M6x1
XV-1P/5.9	1.260	97,0	46,8	85,0	ø12	30	M6x1	ø12	30	M6x1
XV-1P/6.5	1.300	98,5	48,0	86,5	ø12	30	M6x1	ø12	30	M6x1
XV-1P/7.8	1.360	103,5	50,0	91,5	ø12	30	M6x1	ø12	30	M6x1
XV-1P/9.8	1.500	112,5	54,5	100,5	ø12	30	M6x1	ø12	30	M6x1

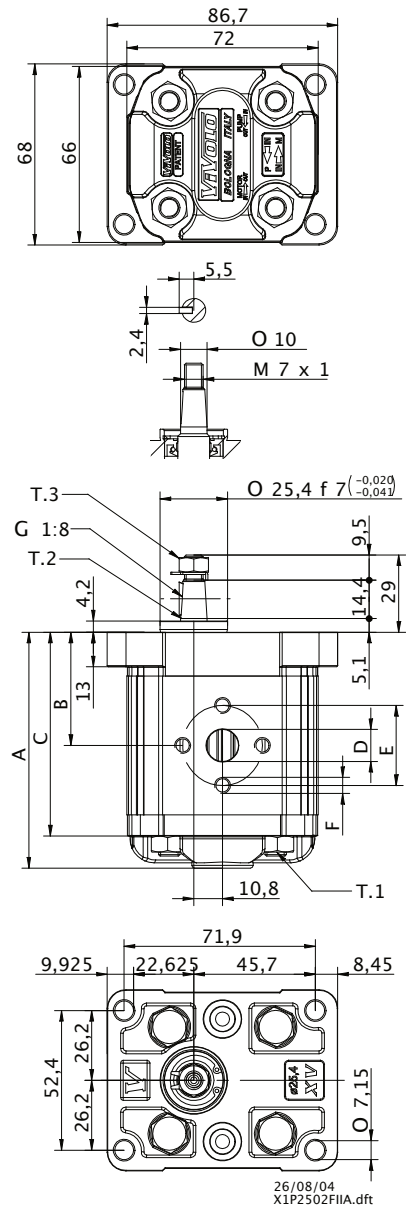

26/08/04
 X1P2502FIIA.dft

T.1 = 24.5±29.4 [Nm] - screw tightening torque M8

T.3 = 11.5 [Nm] - torque wrench setting 11

T.2 = 43 [Nm] - admissible shaft torque (N.B. When choosing a shaft, always check the admissible torque).

Table of variations

ø25.4 FLANGE

ø25.4 FLANGE				Shaft		Cover			
Left rotation		Right rotation				Left rotation	Right rotation		
	01		02	C0001 - Tapered T.2 = 43 [Nm] 	F	CF002 - Milled shank T.2 = 13.8 [Nm] 	D		A
	03		04	SCF04 - Splined T.2 = 22.6 [Nm] m=1.6 Z=6 DIN 5482-12x9 	J	SCF02 - Splined T.2 = 42.8 [Nm] m=0.75 Z=15 	L		B
	05		06	SCF01 - Splined T.2 = 42.8 [Nm] m=0.75 Z=15 	Q	SCF03 - Splined T.2 = 42.8 [Nm] m=0.75 Z=15 	R		C
	07		08						D

Displacement	
TYPE	
XV-1P/0.9	16
XV-1P/1.2	17
XV-1P/1.7	18
XV-1P/2.2	20
XV-1P/2.6	21
XV-1P/3.2	23
XV-1P/3.8	25
XV-1P/4.3	27
XV-1P/4.9	29
XV-1P/5.9	31
XV-1P/6.5	32
XV-1P/7.8	34
XV-1P/9.8	36

Standard bodies						
Displacement cm3/rev	Standard threads					
	0.9	I-I	B-B	J-J	B-Z	Z-Z
1.2	I-I	B-B	J-J	B-Z	Z-Z	G-F
1.7	I-I	B-B	J-J	B-Z	Z-Z	G-F
2.2	I-I	B-B	J-J	B-Z	Z-Z	G-F
2.6	I-I	B-B	J-J	B-Z	Z-Z	G-F
3.2	I-I	B-B	J-J	B-Z	Z-Z	G-F
3.8	I-I	B-B	J-J	B-Z	Z-Z	G-F
4.3	I-I	B-B	J-J	B-Z	Z-Z	G-F
4.9	I-I	B-B	J-J	B-Z	Z-Z	G-F
5.9	I-I	B-B	J-J	B-Z	Z-Z	G-F
6.5	I-I	B-B	J-J	B-Z	Z-Z	G-F
7.8	I-I	B-B	J-J	B-Z	Z-Z	G-F
9.8	I-I	B-B	J-J	B-Z	Z-Z	G-F

Table showing standard flange and thread combinations available in stock

	N
Internal drainage	
	O
External drainage	

Body (threads/flanges)							
	A		B		C		D
	E		F		G		
	H		I		J	Closed Body	Z