

G2 series industrial LCD turbine flowmeters

G2 series industrial turbines are a cost effective range of turbines available in a wide range of materials and connection types. Flows from 4 to 760 l/min and a wide fluid compatibility offering make these the perfect choice for any industrial flow metering requirement. Accuracies range from +/-0.75% on larger models to +/-1.5% on smaller models.



G2 in Stainless Steel - model S

G2 in High pressure Stainless Steel - model H

G2 in Aluminium - model A

G2 in Brass - model B



G2 in PVC - model C

G2 in PVDF - model P



G2 in Stainless Steel ANSI flanged - model SF

G2 in Stainless Steel with hygienic Tri-Clover connections - model ST

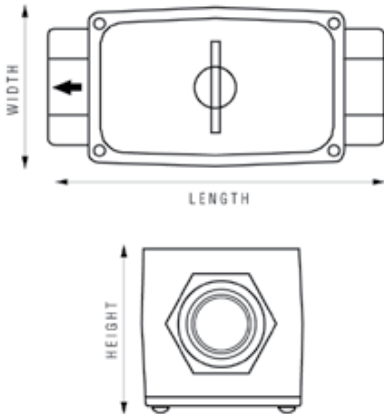

Dimensional Information

Model	Size	Flow rate l/min	Max pressure bar	Length mm	Height mm	Width mm	Model	Size	Flow rate l/min	Max pressure bar	Length mm	Height mm	Width mm
A05	1/2"	3.8 - 38	21	107	46	51	H20	2"	76 - 760	207	160	81	84
A07	3/4"	7.6 - 76	21	109	51	51	P05	1/2"	3.8 - 38	10.2	185	81	53
A10	1"	19 - 190	21	114	56	51	P10	1"	19 - 190	10.2	206	84	71
A15	1.1/2"	38 - 380	21	135	71	68	S05	1/2"	3.8 - 38	102	107	46	51
A20	2"	76 - 760	21	160	81	84	S07	3/4"	7.6 - 76	102	109	51	51
B05	1/2"	3.8 - 38	21	107	46	51	S10	1"	19 - 190	102	114	56	51
B07	3/4"	7.6 - 76	21	109	51	51	S15	1.1/2"	38 - 380	102	135	71	68
B10	1"	19 - 190	21	114	56	51	S20	2"	76 - 760	102	160	81	84
B15	1.1/2"	38 - 380	21	135	71	68	S10F	1"	19 - 190	Flange	171	108	108
B20	2"	76 - 760	21	160	81	84	S15F	1.1/2"	38 - 380	Flange	203	127	127
C05	1/2"	3.8 - 38	10.2	185	81	53	S20F	2"	76 - 760	Flange	241	152	152
C10	1"	19 - 190	10.2	206	84	71	S05T	1/2"	3.8 - 38	Flange	127	51	46
H05	1/2"	3.8 - 38	10.2	107	46	51	S07T	3/4"	7.6 - 76	Flange	127	51	51
H07	3/4"	7.6 - 76	10.2	109	51	51	S10T	1"	19 - 190	Flange	140	51	56
H10	1"	19 - 190	10.2	114	56	51	S15T	1.1/2"	38 - 380	Flange	165	68	71
H15	1.1/2"	38 - 380	10.2	135	71	68	S20T	2"	76 - 760	Flange	178	84	81

Dimensions are for reference only and may vary by model

G2 series industrial LCD turbine flowmeters

Options & Ordering Information

